

Attachment # 1
Subdivision and Development Control Bylaw No. 7142, 2007,
Miscellaneous Amendments Bylaw No. 8515, 2025

**CORPORATION OF THE CITY OF NEW WESTMINSTER
BYLAW NO. 8515, 2025**

A Bylaw to Amend Subdivision and Development Control Bylaw No. 7142, 2007

The Council of The Corporation of the City of New Westminster in open meeting assembled ENACTS AS FOLLOWS:

Citation

1. This Bylaw may be cited for all purposes as “Subdivision and Development Control Bylaw No. 7142, 2007, Miscellaneous Amendments Bylaw No. 8515, 2025.”

Amendments

2. Subdivision and Development Control Bylaw No. 7142, 2007 is amended by:
 - a) In Part Four, Works and Services, amending Section 4.3 (b) to add “and 4.5” after 4.4”
 - b) In Part Four, Works and Services, deleting Section 4.5 and replacing with:

“4.5 The Security deposit required to be provided under Section 4.3 shall be in the form of cash, a certified cheque payable to the City, or another form that is an alternative to standard forms of security, restricted to a Letter of Assurance from provincial and federal public bodies that is considered and approved on a case-by-case basis by the City’s Director of Finance and Director of Engineering, or a clean, irrevocable letter of credit acceptable to the City and substantially in the form prescribed in Schedule “E” of this Bylaw.”
 - d) Inserting a Section Cover Page before SCHEDULE “A” with the following text:

SCHEDULE “A”

to

CORPORATION OF THE CITY OF NEW WESTMINSTER

BYLAW NO. 7142, 2007

WORKS AND SERVICES AGREEMENT

c) In SCHEDULE "A", adding a header to all of the pages with the following text:

City of New Westminster
SCHEDULE "A"

Works and Services Agreement

March 10, 2025

d) In SCHEDULE "A" Section 16:

- i) In subsection (b), deleting "or"
- ii) In subsection (c), deleting the period "." after "Developer"
- iii) In subsection (c), adding ", or" after "Developer"
- iv) Adding subsection (d) as follows:

(d) "another form that is alternative to security, restricted to a Letter of Assurance from provincial or federal government bodies considered approved on a case-by-case basis by the City's Director of Finance and Director of Engineering."

e) In SCHEDULE "B" Section Cover Page

- i) On the Section Cover Page, adding "SCHEDULE B" before "City Of New Westminster Design Criteria"
- ii) On the Section Cover Page, deleting "#369461 and "July 8, 2019"

f) In SCHEDULE "B" Section 2:

- i) Deleting the comma "," at the end of the paragraph and replacing it with a period "."

g) In SCHEDULE "B" Section 3:

- i) In the header of Section 3, Storm Drainage System, replacing "Section 2" with "Section 3"
- ii) In Subsection 3.1 General, adding "Provision of a Design Brief for design related work may be requested, at the discretion of the Director of Engineering." as a new paragraph between the paragraph ending "...and provincial statutes." and the paragraph beginning "The Consulting Engineer..."

h) In SCHEDULE "B" Section 4:

- i) In Subsection 4.1 General, adding "Provision of a Design Brief for design related work may be requested, at the discretion of the Director of Engineering." as a new paragraph between the paragraph ending "...and

provincial statutes.” and the paragraph beginning “The Consulting Engineer...”

i) In SCHEDULE “B” Section 5:

- i) In Subsection 5.1 General, adding “Provision of a Design Brief for design related work may be requested, at the discretion of the Director of Engineering.” as a new paragraph between the paragraph ending “...and provincial statutes.” and the paragraph beginning “The location of pressure...”

j) In SCHEDULE “B” Section 6:

- i) In Subsection 6.5, Light Pole Spacing, in the first paragraph adding “and powder coated black in a color that is Black (RAL 9005),” after “All poles shall be davit style”
- ii) In Subsection 6.6, Luminaires, Light Source and Smart City, adding “Luminaires shall provide a Kelvin rating of 3000K at 35W or 4000K at 80W and have selectable drivers.” as a new paragraph between the paragraph ending “... and the Supply Authority.” and the subhead “Light Source.”

k) In SCHEDULE “B” Section 7:

- i) In Subsection 7.3.1, deleting the name of table 7.1 and replacing it with “Minimum Vehicle Travel Lanes”
- ii) In Subsection 7.3.1 table 7.1, deleting the text “Lane (standard – additional width may be required)” and replacing with “Lane (Standard)”
- iii) In Subsection 7.3.2 table 7.2, deleting the text “Lane (standard – additional width may be required)” and replacing with “Lane (Standard)”
- iv) In Subsection 7.5.1, deleting the name of table 7.3 and replacing it with “Minimum Driveway Widths”
- v) In Subsection 7.5.1 Table 7.3, deleting “*” after “(m)” in the middle column
- vi) In Subsection 7.5.1 table 7.3, deleting the text “Note: (*) To be confirmed by Consulting Engineer based on the type of vehicle accessing the site.”
- vii) In Subsection 7.9.1, deleting “drainage and” after “Landscaped boulevards will be required in residential areas, or where deemed necessary by the Director of Engineering. The boulevards shall be prepared for boulevard Trees completed with a 1.0m deep New Westminster Planting Blend or approved equal growing medium for the full width of the boulevard, including”
- viii) In Subsection 7.9.1, adding “The provision of irrigation for the purpose of maintaining boulevard trees shall exclude boulevards in Queensborough.”

as a new paragraph between the paragraph ending "...as determined by the Director of Engineering." and subhead 7.9.2.

l) In SCHEDULE "B" Section 8:

- i) In Subsection 8.2.1, deleting the text "The City Parks Department will plant all trees on City property. The developer/contractor is responsible for all site preparation for the street trees and other landscape areas as noted above." and replacing it with "At the developer's cost, trees will be selected by the City's Parks Department from a City Approved nursery based on available soil volume and location. The developer shall retain a City pre-approved contractor to pick-up and plant the trees in accordance with City Specifications."
- ii) In Subsection 8.2.3 deleting the text "The City Parks Department shall select and plant all street trees at the Developers cost. The designer will identify tree spacing requirements." and replacing it with "At the developer's cost, trees will be selected by the City's Parks Department from a City Approved nursery based on available soil volume and location. The developer shall retain a City pre-approved contractor to pick-up and plant the trees in accordance with City Specifications."
- iii) Deleting Subsection 8.2.7 and replacing it with:

"8.2.7 Where required by the City Parks Department for the maintenance of trees located in boulevards or medians in the road right-of-way, an underground sprinkler system shall be provided by the Developer. The System must be capable of providing the necessary irrigation as required and shall be automatically activated through a timed control system. Water source to the irrigation system shall be provided from the property's water service connection. Under special circumstances, irrigation may be required for other landscaping; please refer to the New Westminster Irrigation Specifications and Details. Provision of an irrigation system will be required if 3 or more trees are being proposed for a development frontage. For frontages requiring 2 or less trees, the developer shall provide a financial contribution towards a City Parks Department initiated watering bag program for the establishment period. The provision of irrigation for the purpose of maintaining boulevard trees shall exclude boulevards in Queensborough."
- iv) Deleting Subsection 8.2.8
- v) Replacing the Subsection header "8.2.9 Drawings" with "8.2.8 Drawings"

- m) In SCHEDULE “C” Section Cover Page
 - i) On the Section Cover Page, adding “SCHEDULE C” before “Supplementary Specifications and Detail Drawings”

- n) In SCHEDULE “C” Section 2 In the table below the header List of Approved Materials and Products:

Before the row “Section 16550 – Electrical,” adding the following rows:

Section – Standard Detail Drawings			
Drawing C-12 – Removable Restriction Post			
Bollards	Reliance Foundry	Bollard Post, Model R-8907	

- o) In SCHEDULE “C” Section 3 Supplementary Detail Drawings:
 - i) Deleting Supplemental Drawing No. SDR-9 and replacing it with Schedule 1 attached to and forming part of this bylaw.
 - ii) Deleting Supplemental Drawing No. SDR-10 and replacing it with Schedule 2 attached to and forming part of this bylaw.
 - iii) Inserting Schedule 3 attached to and forming part of this bylaw between Supplemental Drawing No. SDR-10 and Supplemental Drawing No. SDR-11A.
 - iv) Deleting Supplemental Drawing No. SDR-12 and replacing it with Schedule 4 attached to and forming part of this bylaw.

- p) In SCHEDULE “D” Section Cover Page
 - i) On the Section Cover Page, adding SCHEDULE “D” before “Engineering Department Drafting Standards

- q) Inserting a Section Cover Page before SCHEDULE “E” with the following text:

SCHEDULE “E”

INFORMATION SHEET

RE: IRREVOCABLE STANDBY LETTER OF CREDIT

-REQUIRED MINIMUM CONTENT

Consequential Amendments

- 3. Bylaw No. 7142, 2007 is further amended by making such consequential changes as are required to give effect to the miscellaneous amendments particularized in this bylaw, including changes to the table of contents, format and numbering.

GIVEN FIRST READING THIS _____ day of _____ 2025.

GIVEN SECOND READING THIS _____ day of _____ 2025.

GIVEN THIRD READING THIS _____ day of _____ 2025.

ADOPTED THIS _____ day of _____ 2025.

Mayor Patrick Johnstone

Hanieh Berg, Corporate Officer

Schedule 1 to Bylaw 8515, 2025

Schedule C, Section 3 to SUBDIVISION AND DEVELOPMENT CONTROL
BYLAW NO. 7142, 2007

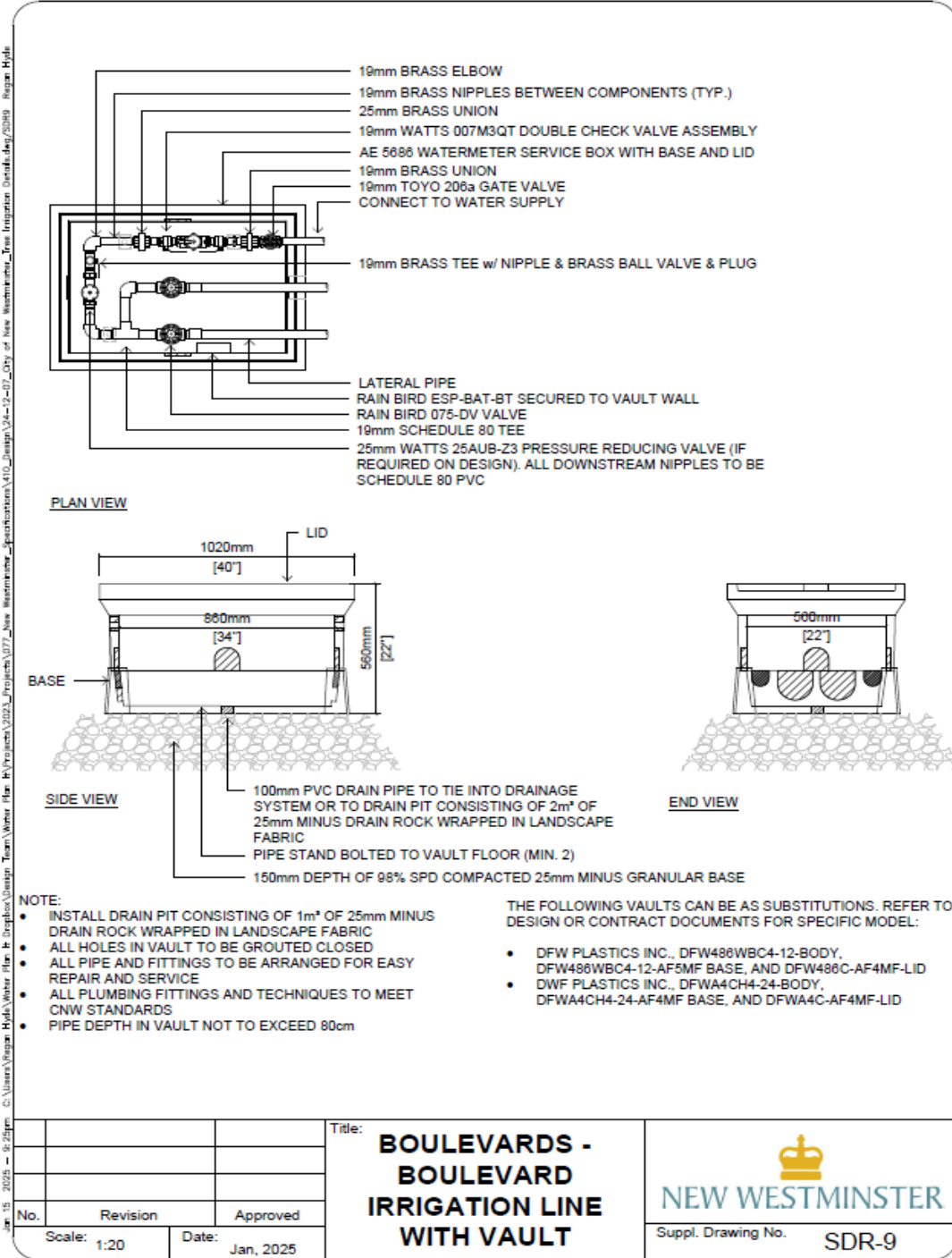

Schedule 2 to Bylaw 8515, 2025

Schedule C, Section 3 to SUBDIVISION AND DEVELOPMENT CONTROL
BYLAW NO. 7142, 2007

Jan 15 2025 - 9:25pm C:\Users\Bryan.Hugh\Water Plan & Dropbox\Design Team\Water Plan & Hydro\Projects\2023_Projects\077_New Westminster_Specifications\10_Design\14-12-07_City of New Westminster_Tree Irrigation Details.dwg/202510_Regen Byla

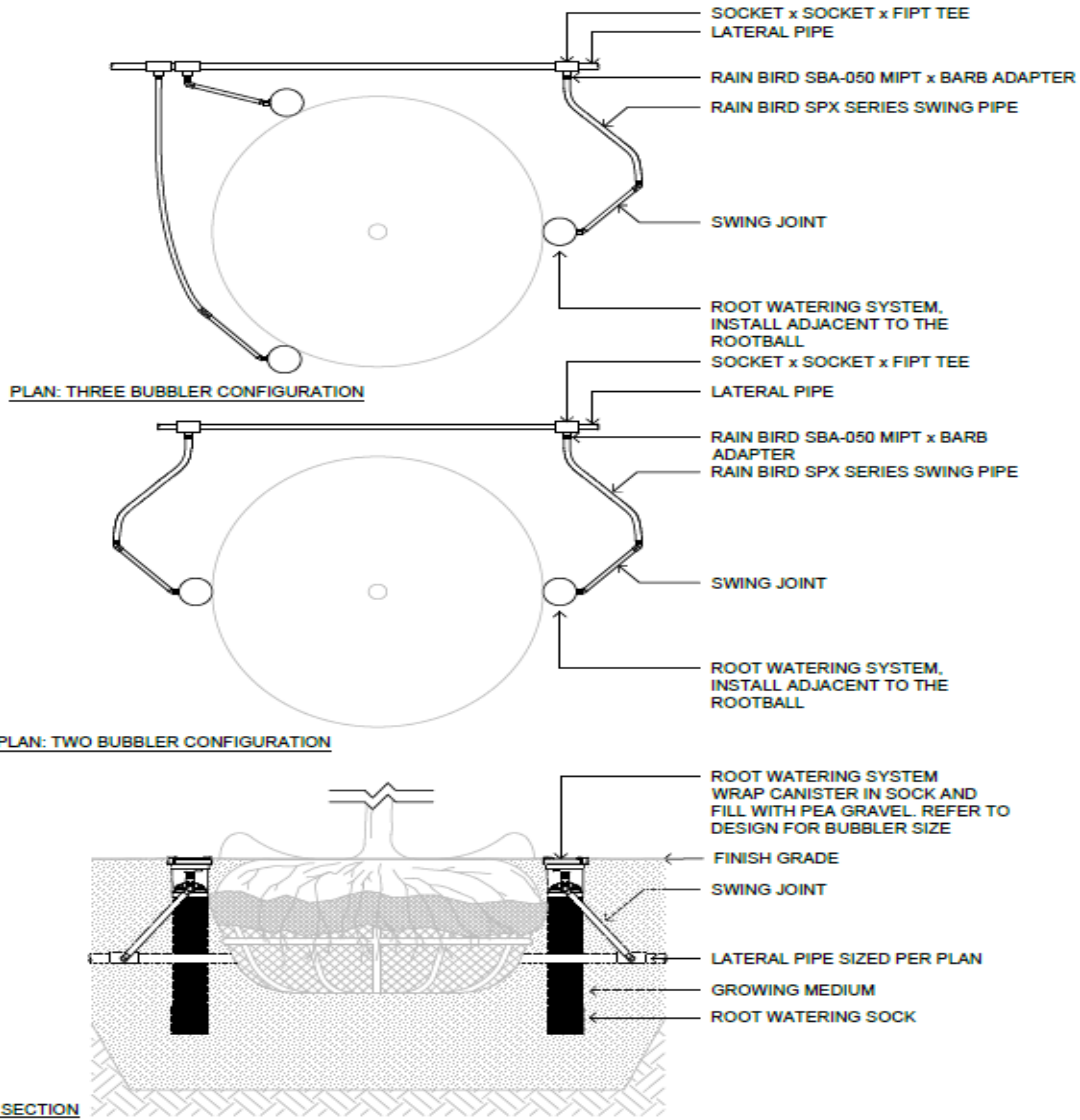

No.	Revision	Approved
Scale: 1:20	Date:	Dec, 2024

Title:

ROOT WATERING SYSTEM

Suppl. Drawing No. **SDR-10**

Schedule 3 to Bylaw 8515, 2025

Schedule C, Section 3 to SUBDIVISION AND DEVELOPMENT CONTROL
BYLAW NO. 7142, 2007

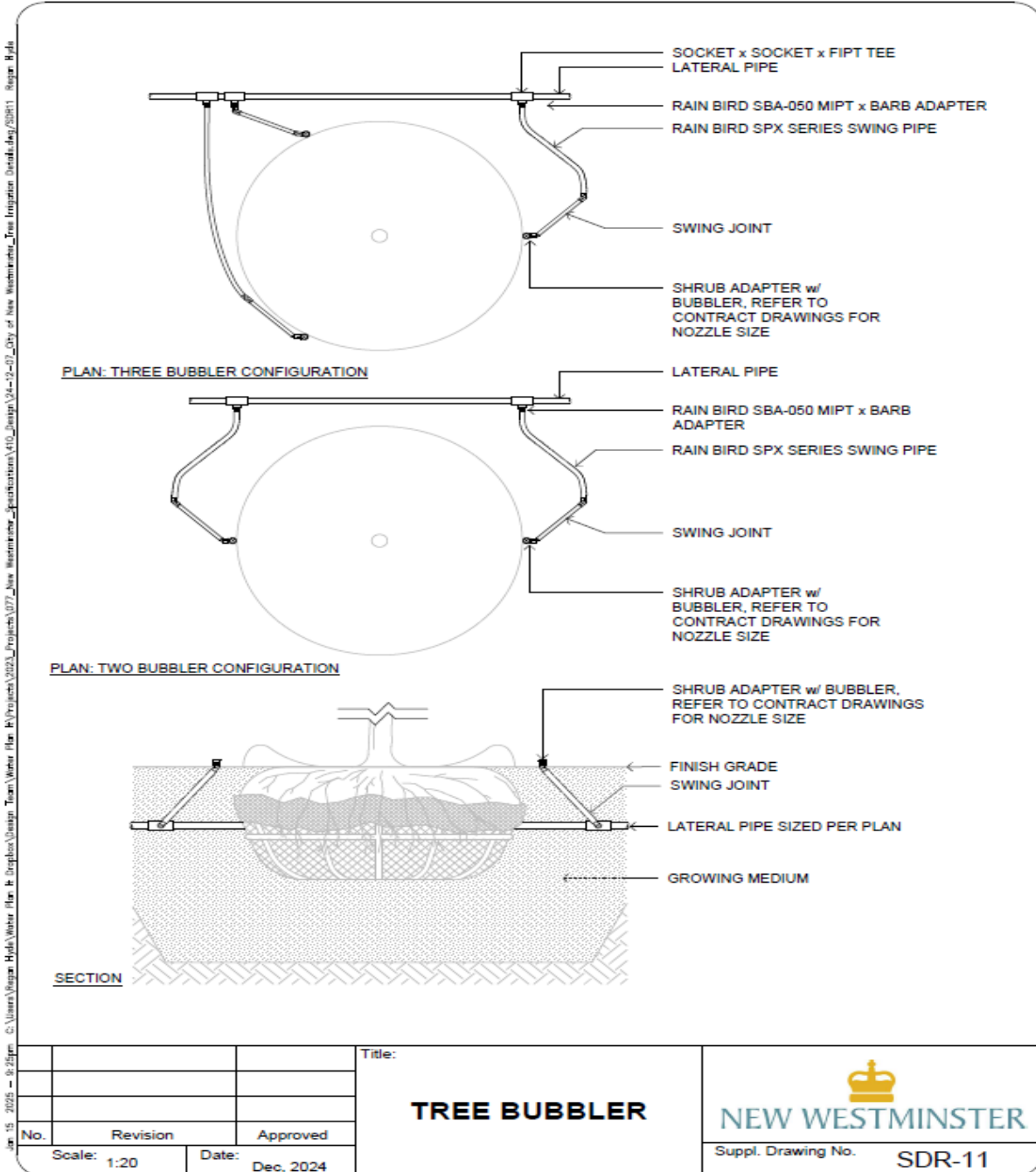

Schedule 4 to Bylaw 8515, 2025

Schedule C, Section 3 to SUBDIVISION AND DEVELOPMENT CONTROL
BYLAW NO. 7142, 2007

